DESPIECE TECNICO

**Lavadoras
Lava-linge
Washing machines
Waschmaschine
Lavatrici
Máquinas de lavar roupa**

Modelos:

LR-18 M

LA-18 M

LR-25 M

LA-25 M



PLATON SERVICE

8 (800) 500-34-47

www.platonservice.com

Noviembre 2010 November

Revisado Enero 2012 January Revised

FAGOR



FAGOR INDUSTRIAL

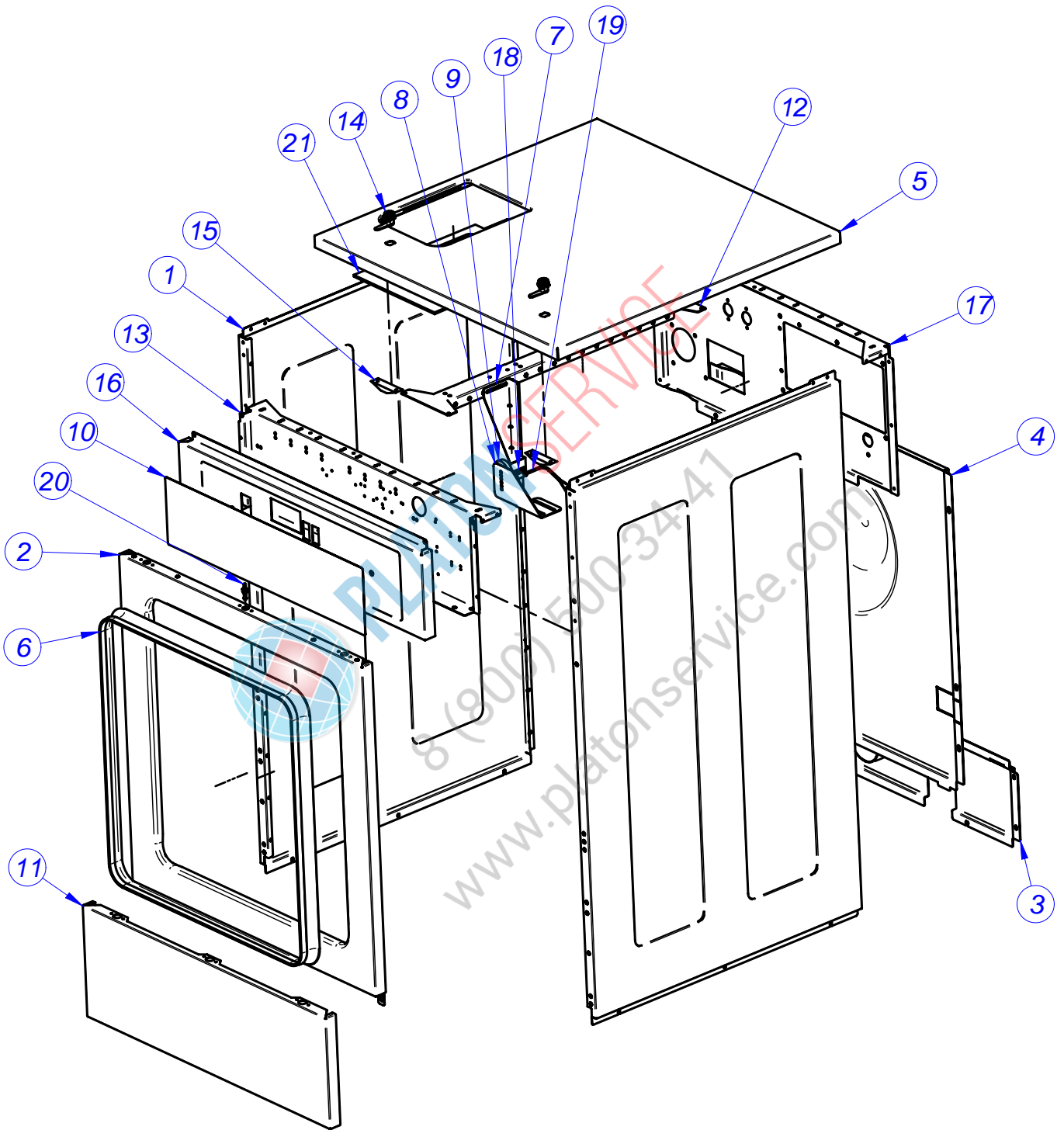

MUEBLE / UNIT																ELIMINADO ELIMINATED	INTRODUCIDO INTRODUCED
ITEM	DENOMINACION	NAME	CODIGO	LR-18		LA-18			LR-25			LA-25					
				M	MA	MP	M	MA	M	MA		MP	M	MA			
1	PANEL LATERAL	SIDE PANEL	P634024000	2	2												
			P630352000			2	2	2									
			P644035000						2	2							
			P640330000								2	2	2				
2	PANEL FRONTAL	FRONT PANEL	P627808000	1	1												
			P637803000			1	1	1	1	1							
			P647804000								1	1	1				
S/Nº	CIERRE MUELLE	LOCK SPRING	X010503000	1	1	1	1	1	1	1	1	1	1	1			
3	PANEL POSTERIOR DESAGUE	DRAINAGE REAR PANEL	P620306000	1	1												
			P630307000			1	1	1									
			P644032000						1	1							
			P640305000								1	1	1				
4	PANEL POSTERIOR	REAR PANEL	P620382000	1	1												
			P630360000			1	1	1	1	1							
			P640337000								1	1	1				
5	ENCIMERA	WORKTOP	P634026000	1	1												
			P630358000			1	1	1									
			P644036000						1	1							
			P640335000								1	1	1				
S/Nº	CANTONERA R1	R1 CORNER	12039188	2	2	2	2	2	2	2	2	2	2	2			
6	CORTINA (METROS)	CURTAIN (METRES)	P620324000	2,5	2,5	2,5	2,5	2,5	2,5	2,5	2,5	2,5	2,5	2,5			
7	PORTA SENSOR DESEQ.	IMBALANCE SENSOR HOLDER	P630315000	1	1	1	1	1			1	1	1				
8	SOPORTE IMAN DESEQ.	IMBALANCE MAGNET HOLDER	P627063000			1	1	1			1	1	1				
9	IMAN DESEQUILIBRIO	IMBALANCE MAGNET HOLDER	P620337000			1	1	1			1	1	1				
10	ADHESIVO	ADHESIVE	P623039000			1					1						
			P623038000	1			1		1			1					
			P623040000		1			1		1			1				
11	ZOCALO	SKIRTING	P627807000	1	1												
			P637802000			1	1	1	1	1							
			P647803000								1	1	1				
	KIT ZOCALO 18	ZOCALO KIT 18	1300000197														
	KIT ZOCALO 25	ZOCALO KIT 25	1300000198														
12	TRAVESAÑO CUBETERA	TRAY CROSS PIECE	P634025000	2	2							2	2	2			
			P630357000			2	2	2									
			P644037000						2	2							

ITEM	DENOMINACION	NAME	CODIGO	MUEBLE / UNIT												ELIMINADO ELIMINATED	INTRODUCIDO INTRODUCED		
				LR-18		LA-18			LR-25			LA-25							
				M	MA	MP	M	MA	M	MA		MP	M	MA					
13	CONTRAPORTAMANDOS	COUNTERCONTROL HOLDER	P620373000	1															
			P620381000		1														
			P630353000			1	1		1										
			P630359000					1		1									
			P640331000										1	1					
14	CERRADURA	LOCK	P620351000	2		2	2		2				2	2					
			P620387000		2			2		2					2				
15	RAMPA CIERRE ENCIMERA	WORKTOP LOCK RAMP	P620379000	2	2		2	2	2	2			2	2	2				
16	PORTAMANDOS	CONTROL HOLDER	P620374000	1															
			P620380000		1														
			P630354000			1	1		1										
			P630355000					1		1									
			P640332000										1	1					
S/Nº	INTERRUPTOR DE SETA ROJO	RED MUSHROOM SWITCH	P640333000												1				
			Z513005000						1	1		1	1	1					
17	SOPORTE ELECTROVALVULAS	SOLENOID VALVE SUPPORT	P620372000	1	1														
			P630356000				1	1	1	1	1								
			P640334000										1	1	1				
18	AMARRRE SENSOR DESEQUILIB.	IMBALANCE SENSOR FASTENIN.	Z203010000				1	1	1				1	1	1				
19	SENSOR DESEQUILIBRIO	SENSOR IMBALANCE	Z203009000				1	1	1				1	1	1				
20	PITON	PITON	X012612000	10	10		10	10	10	10			10	10	10				
21	JUNTA CUBETA	TRAY SEAL	P610360000	1	1		1	1	1	1			1	1	1				

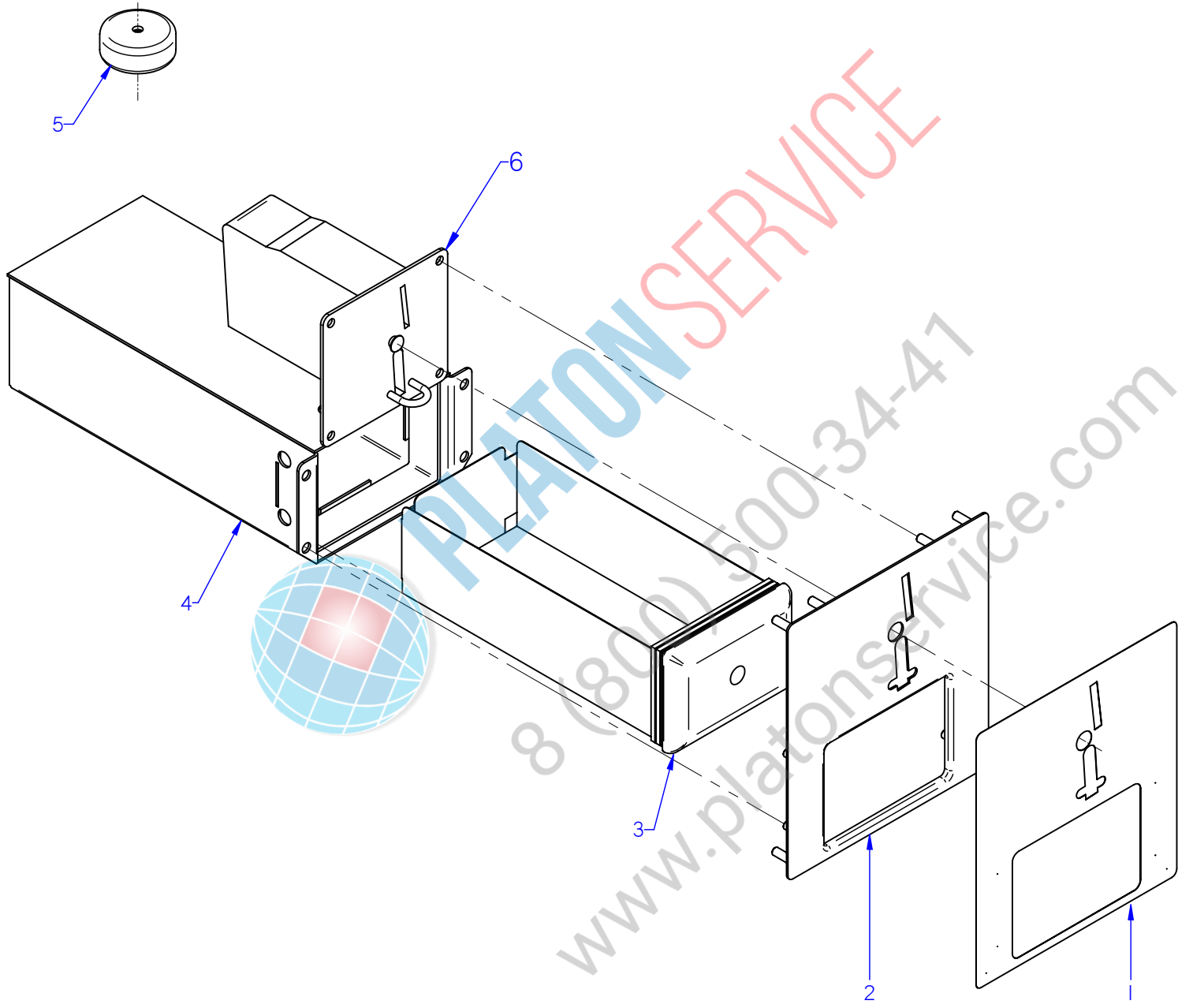

KIT MONEDERO

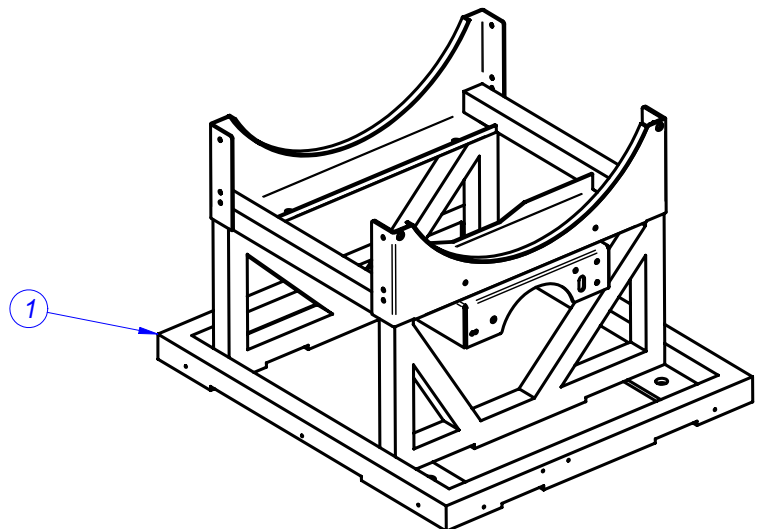
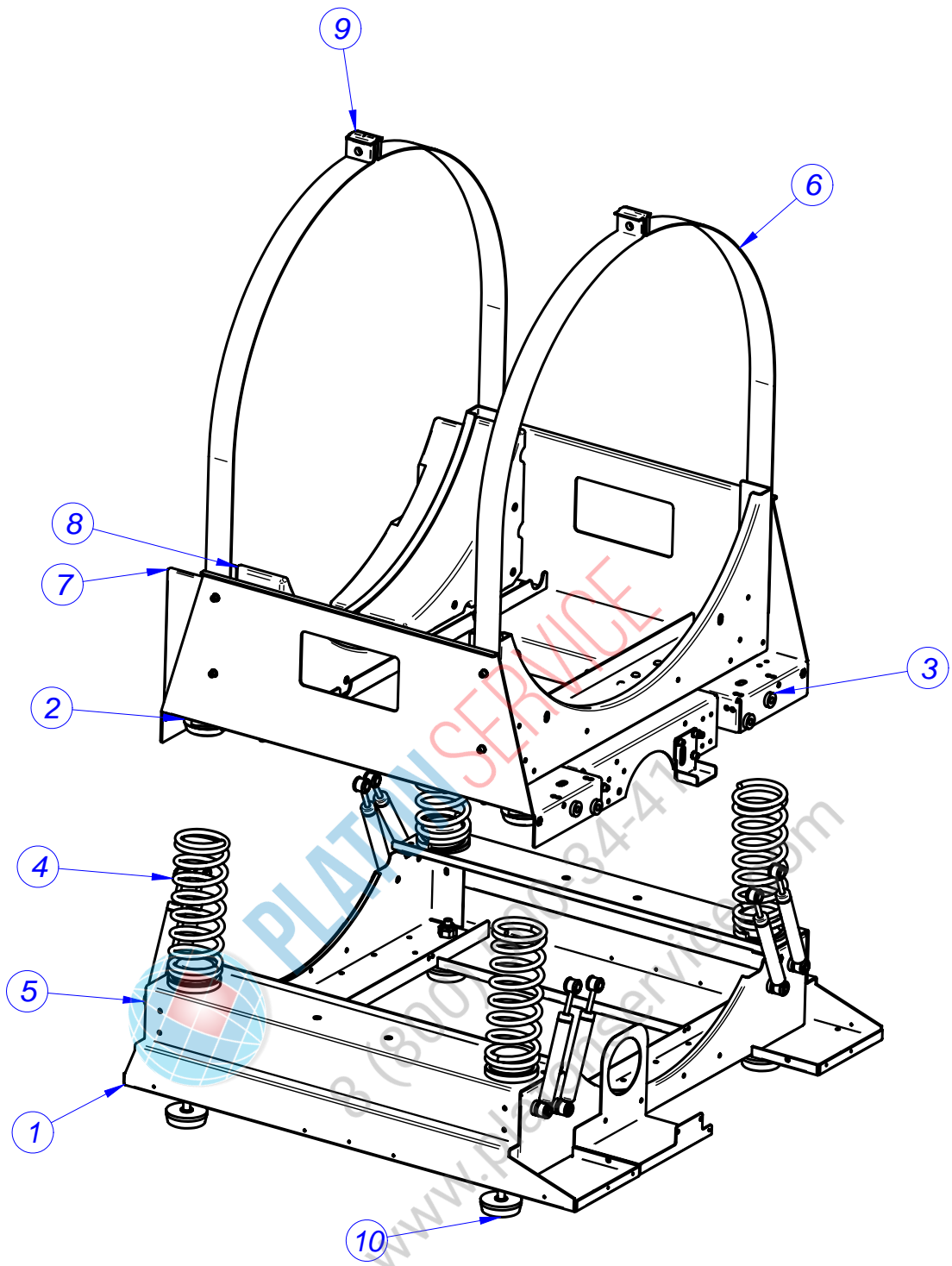

CUNA - ARMAZON / CRADLE - FRAME														ELIMINADO ELIMINATED	INTRODUCIDO INTRODUCED			
ITEM	DENOMINACION	NAME	CODIGO	LR-18		LA-18			LR-25		LA-25							
				M	MA	MP	M	MA	M	MA		MP	M			MA		
1	ARMAZON	FRAME	P634001000	1	1										02,05,11			
			P634031000	1	1												02,05,11	
			P630104000			1	1	1										
			P644001000							1	1						02,05,11	
			P644042000							1	1							02,05,11
			P640101000									1	1	1				
2	BASE MUELLE	SPRING BASE	P620106000			8	8	8										
			P640111000								8	8	8					
3	CASQUILLO AMORTIGUADOR	DAMPER BUSHING	P620107000			16	16	16				16	16	16				
4	MUELLE	SPRING	P630106000			4	4	4										
			P640108000								4	4	4					
5	AMORTIGUADOR	DAMPER	P620115000			8	8	8										
			P630111000								8	8	8					
6	CUNA	CRADLE	P630207000			1	1	1										
			P640201000								1	1	1					
7	CONTRAPESO ANTERIOR	FRONT COUNTERWEIGHT	P630212000			2	2	2										
			P640205000								2	2	2					
8	CONTRAPESO POSTERIOR	REAR COUNTERWEIGHT	P630208000			2	2	2										
			P640208000								2	2	2					
9	AMARRE ABRAZADERA	CLAMP FASTENING	P640215000	4	4	4	4	4	4	4	4	4	4	4				
10	PATA	LEG	P626521000			4	4	4				4	4	4				

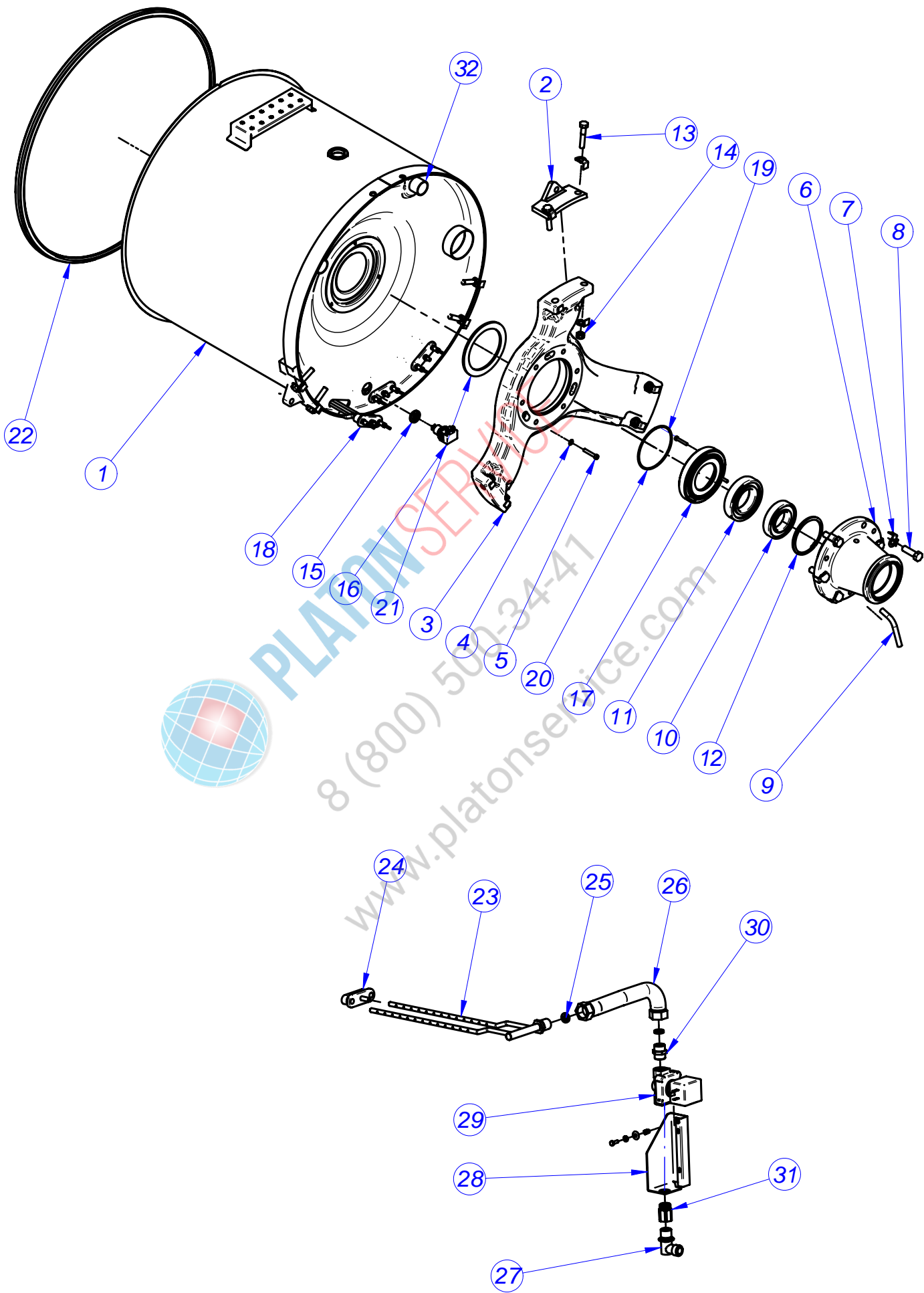

CUBA / TUB															ELIMINADO ELIMINATED	INTRODUCIDO INTRODUCED			
ITEM	DENOMINACION	NAME	CODIGO	LR-18			LA-18			LR-25			LA-25						
				E	AC	V	E	AC	V	E	AC	V	E	AC			V		
1	CUBA	TUB	P634012000	1	1	1										01,12,10			
			P634029000	1	1	1												01,12,10	
			P636107000				1	1	1										
			P644012000							1	1	1					01,12,10		
			P644040000							1	1	1						01,12,10	
			P646105000								1	1	1						
S/Nº	TAPÓN DESAGÜE	DRAIN PLUG	T305052000	1	1	1	1	1	1	1	1	1	1	1					
2	APOYO TORNILLOS	SCREW SUPPORT	P626014000	1	1	1													
			P636009000				1	1	1	1	1	1							
			P646012000										1	1	1				
3	REFUERZO FONDO CUBA	TUB BASE REINFORCEMENT	P626001000	1	1	1													
			P636001000				1	1	1	1	1	1							
			P646014000										1	1	1				
4	ARANDELA	WASHER	Q232040000	3	3	3	3	3	3	3	3	3	5	5	5				
5	TORN. INTERIOR REFUERZO	HEXAGONAL INTERIOR REINFOR	Q122045000	3	3	3	3	3	3	3	3	3	5	5	5				
6	SOPORTE RODAMIENTOS	BEARING SUPPORT	P626002000	1	1	1													
			P636002000				1	1	1	1	1	1							
			P646015000										1	1	1				
7	ARANDELA SEGURIDAD	SAFETY WASHER	Q271302000	6	6	6													
			Q271306000	12	12	12	18	18	18	18	18	18							
			Q271304000										30	30	30				
8	TORN. SOP. RODAMIENTOS	BEARING SUPPORT SCREW	Q151529000	6	6	6													
			Q151589000				6	6	6	6	6	6							
			Q151590000										10	10	10				
9	TUBO EVACUACION	DRAINAGE PIPE	P626015000	1	1	1	1	1	1	1	1	1	1	1	1				
10	RODAMIENTO EXTERIOR	OUTER BEARING	P626008000	1	1	1													
			P626009000				1	1	1	1	1	1							
			P644904000										1	1	1				
11	RODAMIENTO INTERIOR	INNER BEARING	P626009000	1	1	1													
			P636008000				1	1	1	1	1	1							
			P644903000										2	2	2				
12	ANILLO SEGURIDAD	CIRCLIP	Q301030000	1	1	1													
			Q301036000				1	1	1	1	1	1							
			Q301045000										1	1	1				
13	TORN. REFUERZO CUBA	TUB REINFORCEMENT SCREW	Q151530000	6	6	6													
			Q151535000				6	6	6	6	6	6							
			Q151590000										10	10	10				
14	TUERCA REFUERZO CUBA	TUB REINFORCEMENT NUT	Q221338000	6	6	6	6	6	6	6	6	6	6						
			Q221347000										10	10	10				
15	SOP.TERMOSTATO 1001713	THERMOSTAT SUPPORT 1001713	N503017000	1	1	1	1	1	1	1	1	1	1	1	1				

CUBA / TUB																ELIMINADO ELIMINATED	INTRODUCIDO INTRODUCED	
ITEM	DENOMINACION	NAME	CODIGO	LR-18			LA-18			LR-25			LA-25					
				E	AC	V	E	AC	V	E	AC	V	E	AC	V			
16	SONDA TEMPERATURA	TEMPERATURE PROBE	P503025000	1	1	1	1	1	1	1	1	1	1	1	1			
17	CASQUILLO CONTRARETEN	COUNTSEAL BUSHING	P626003000	1	1	1												
			P636003000				1	1	1	1	1	1						
			P646003000										1	1	1			
18	RESISTENCIA CALENTAMIENTO	HEATING RESISTOR	P633002000	3	1		3	1										
			P533001000							3	1		3	1				
19	TORN. CASQ. CONTRARETEN	COUNTERSEAL BUSHING SCREW	Q122034000	3	3	3	3	3	3	3	3	3	3	3	3			
20	JUNTA TÓRICA	O-RING	Q307075000	1	1	1												
			Q307077000				1	1	1	1	1	1						
			Q307083000										1	1	1			
21	JUNTA CASQ. CONTRARETEN	COUNTERSEAL BUSHING SCREW	P616013000	1	1	1												
			P636011000				1	1	1	1	1	1						
			P646017000										1	1	1			
22	JUNTA CUBA	TUB SEAL	P626110000	1	1	1												
			P636108000				1	1	1	1	1	1						
			P646110000										1	1	1			
23	INYECTOR VAPOR 10,13,18	STEAM JET 10,13,18	P615001000			1			1		1							
			P645002000												1			
24	CIERRE INYECTOR	INJECTOR LOCK	P445011000			1			1		1			1				
25	ARANDELA VAPOR 10, 13, 18	STEAM WASHER 10, 13, 18	P615002000			2			2									
			P535024000								2			2				
26	MANGUERA VAPOR	STEAM HOSE	P525005000			1			1									
			P545011000								1			1				
27	CODO	L-BEND	S115013000			1			1									
			Z718421000												1			
28	SOPORTE VALVULA	VALVE SUPPORT	P620327000			1			1									
			P645001000												1			
29	VALVULA VAPOR	STEAM VALVE	P615003000			1			1									
			P535023000									1						
30	RACOR M-M	M-M CONNECTION	S205023000			1			1					1				
			Z102301000													1		
31	RACOR H-M	H-M CONNECTION	X162101000			1			1					1				
32	TAPON VAPOR CUBA	VAPOR PLUG CUBA	P626135000				1	1	1					1	1	1	01.12.10	

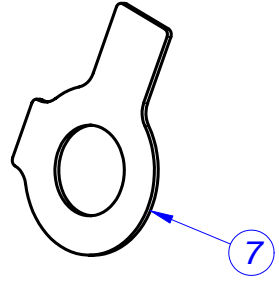
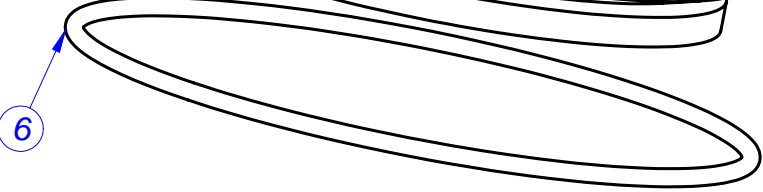
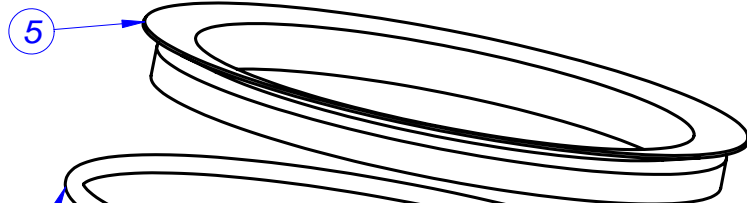
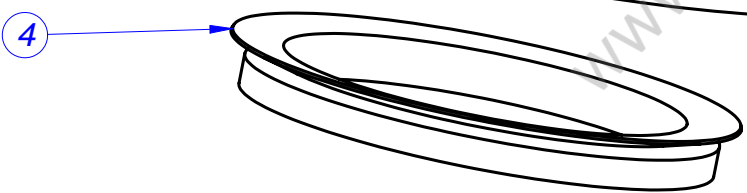
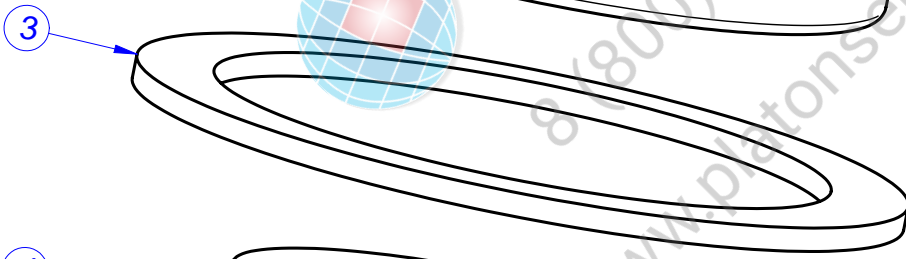
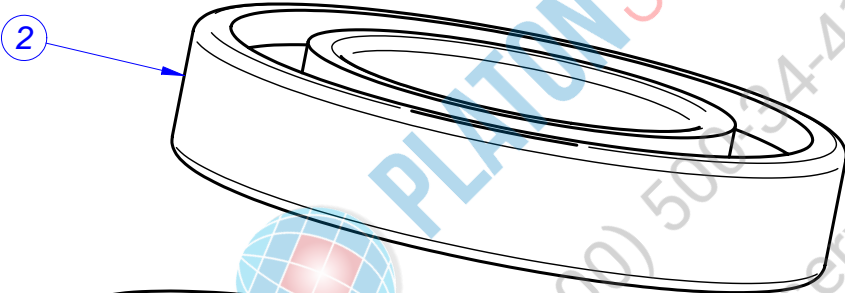
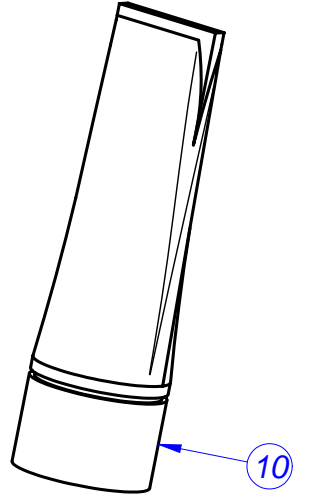
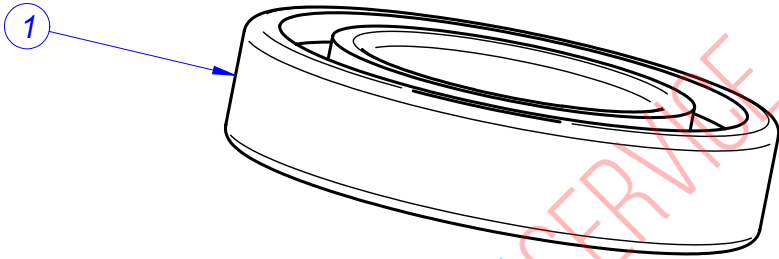
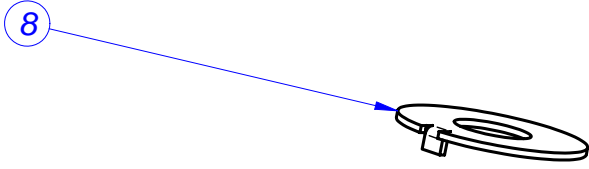
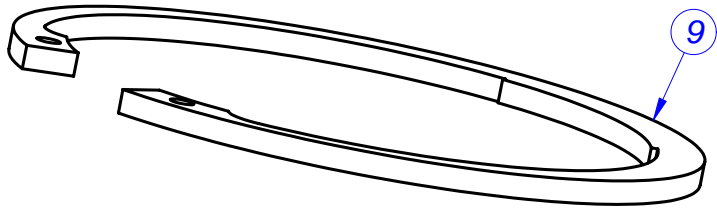

PLATON SERVICE
8 (800) 500-34-47
www.platonservice.com

KIT RODAMIENTOS / BEARING KIT								ELIMINADO ELIMINATED	INTRODUCIDO INTRODUCED
ITEM	DENOMINACION	NAME	CODIGO	LR-18	LA-18	LR-25	LA-25		
	KIT RODAMIENTOS 13	BEARING KIT 13	1300000084	1					
	KIT RODAMIENTOS 18	BEARING KIT 18	1300000085		1	1			
	KIT RODAMIENTOS 25	BEARING KIT 25	1300000164				1		
1	RODAMIENTO EXTERIOR	OUTER BEARING	P626008000	1					
			P626009000		1	1			
			P644904000				1		
2	RODAMIENTO INTERIOR	INNER BEARING	P626009000	1					
			P636008000		1	1			
			P644903000				2		
3	JUNTA CASQ. CONTRARETEN	COUNTERSEAL BUSHING SCREW	P616013000	1					
			P636011000		1	1			
			P646017000				1		
4	RETEN V-RING 1	V-RING 1 RETAINER 1	P624914000	1					
			P634912000		1	1			
			P644916000				1		
5	RETEN V-RING 2	V-RING RETAINER 2	P624913000	1					
			P634911000		1	1			
			P644915000				1		
6	JUNTA TÓRICA	O-RING	Q307075000	1					
			Q307077000		1	1			
			Q307083000				1		
7	ARANDELA SEGURIDAD	SAFETY WASHER	Q271302000	6					
			Q271306000	12	18	18			
			Q271304000				30		
8	ARANDELA SEG. POLEA	SAFETY WASHER PULLEY	Q301329000	1	1	1	1		
			Q301030000	1					
			Q301036000		1	1			
9	ANILLO SEGURIDAD	CIRCLIP	Q301045000				1		
			P536544000	1	1	1	1		
10	GRASA RETENES	GREASE SEALS							

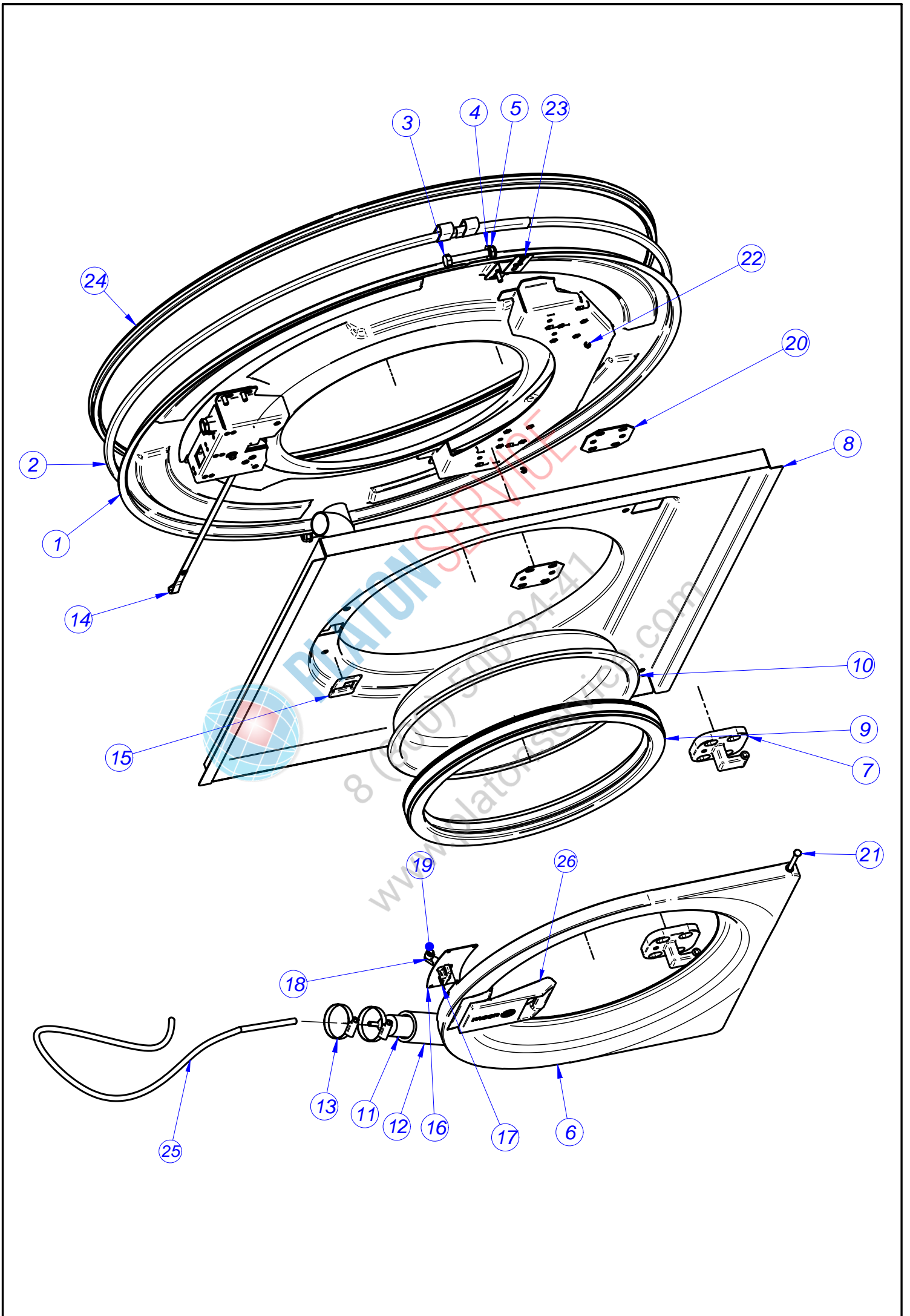

FRENTE CUBA / TUB FRONT								ELIMINADO ELIMINATED	INTRODUCIDO INTRODUCED
ITEM	DENOMINACION	NAME	CODIGO	LR-18	LA-18	LR-25	LA-25		
1	FRENTE CUBA COMPLETO	COMPLETE TUB FRONT	P626112000	1					
			P636110000		1	1			
			P646008000					1	
2	CIERRE CUBA	TUB LOCK	P626118000	1					
			P636112000		1	1			
			P646107000					2	
3	TORNILLO CIERRE CUBA	TUB LOCK SCREW	Q011369000	1	1	1	2		
4	ARAND. CIERRE	GROWER LOCK	Q232060000	2	2	2	4		
5	TUERCA CIERRE CUBA	TUB LOCK NUT	Q221306000	1	1	1	2		
6	PUERTA CON MANETA	DOOR WITH LEVER	P620532000	1	1	1	1		
S/Nº	PUERTA 13,8	DOOR 13,8	P620503000	1	1	1	1		
S/Nº	MANETA PUERTA FAGOR	DOOR HANDLE FAGOR	P620533000	1	1	1	1		
S/Nº	POMO FAGOR 2010	KNOB FAGOR 2010	P640502000	1	1	1	1		
S/Nº	TOR ALLEN M6x20 DIN 7984	ALLEN SCREW M6x20 DIN 7984	Q152062000	2	2	2	2		
S/Nº	ARANDELA SEGURIDAD 4	WASHER SAFETY 4	Q272020000	2	2	2	2		
S/Nº	MUELLE CIERRE	SPRING LOCK	P620510000	1	1	1	1		
S/Nº	PASADOR CIERRE	LOCKING PIN	P620511000	1	1	1	1		
7	BISAGRA PUERTA	DOOR HINGE	P620502000	2	2	2	2		
8	FONDO PUERTA	DOOR BASE	P620501000	1	1	1	1		
S/Nº	PERFIL GOMA GRIS EN U 12*6	GREY RUBBER PROFILE U12*6	3673700000	1	1	1	1		
9	JUNTA PUERTA	DOOR SEAL	P620528000	1	1	1	1		
10	MIRILLA PUERTA	DOOR WINDOW	P530503000	1	1	1	1		
11	CAMARA PRESOSTATO	PRESSURE SWITCH	Q232060000	1	1	1	1		
12	CONDUCTO UNION	PIPE UNION	P502106000	1	1	1	1		
13	ABRAZADERA	CLAMP	Q881306000	2	2	2	2		
14	CIERRE COMPLETO	COMPLETE LOCK	P620531000	1	1	1	1		
15	EMBELLECEDOR CIERRE	LOCK TRIM	P620515000	1	1	1	1		
16	TAPA CIERRE	LID CLOSURE	P627816000	1	1	1	1		
17	GANCHO CIERRE	LOCK HOOK	P620505000	1	1	1	1		
18	CASQUILLO	BUSHING	P610506000	1	1	1	1		
19	ANILLO SEGURIDAD	CIRCLIP	Q302061000	1	1	1	1		
20	CALZO BISAGRA	HINGE WEDGE	P620521000	4	4	4	4		
21	PASADOR PUERTA	DOOR PIN	P620514000	2	2	2	2		
22	ARANDELA SEGURIDAD 4	SAFETY WASHER 4	Q272020000	2	2	2	2		
23	SOPORTE CONDUCTO	PIPE SUPPORT	P626128000	1	1	1	1		
24	JUNTA CUBA	TUB SEAL	P626110000	1					
			P636108000		1	1			
			P646110000				1		
25	TUBO GOMA NEGRO Ø 8*4	BLACK RUBBER HOSE Ø 8*4	3702400000	1	1	1	1		
26	POMO FAGOR 2010	FAGOR 2010 KNOB	P640502000	1	1	1	1		

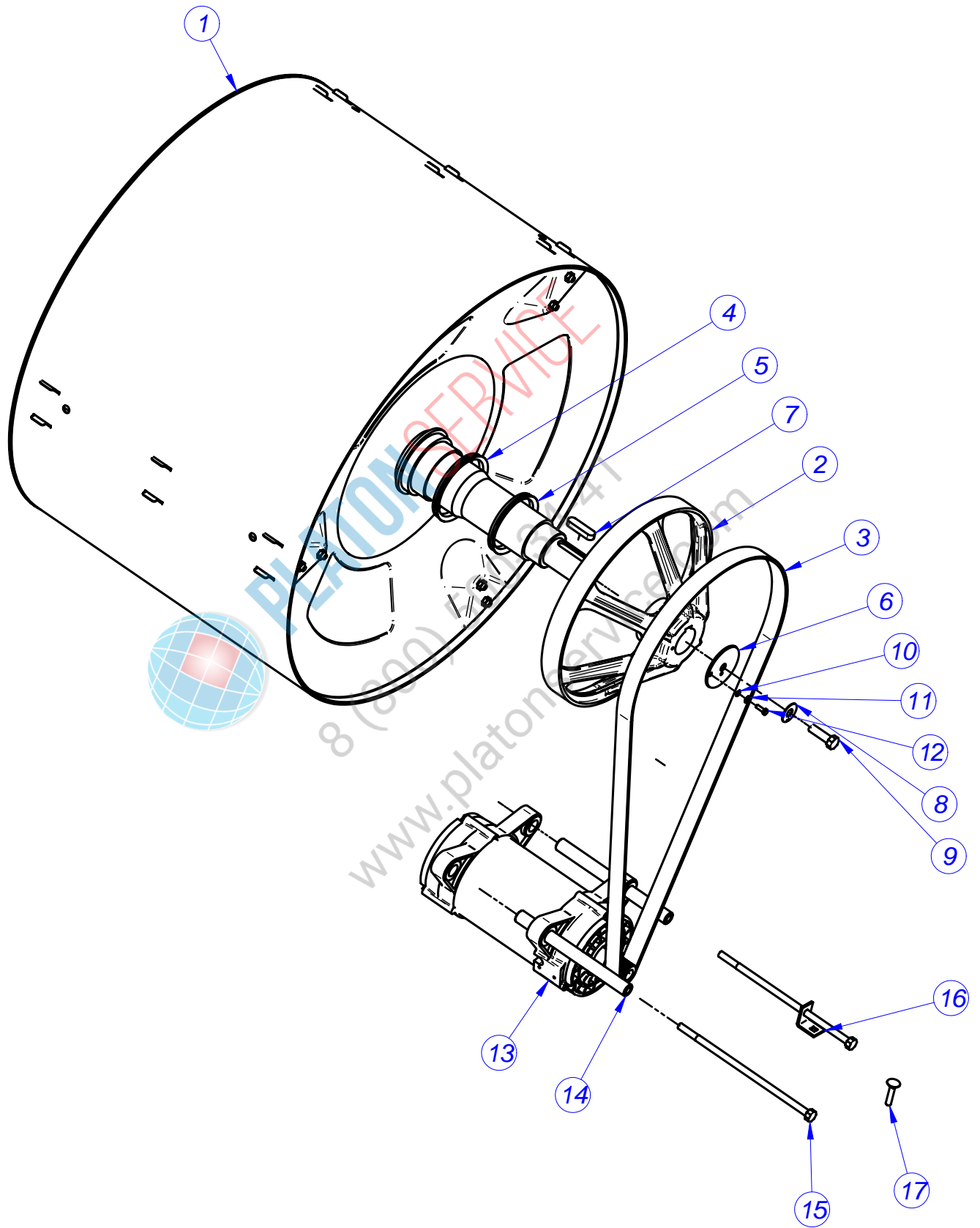

TAMBOR / DRUM

ITEM	DENOMINACION	NAME	CODIGO	LR-18		LA-18			LR-25			LA-25			ELIMINADO ELIMINATED	INTRODUCIDO INTRODUCED		
				M	MA	MP	M	MA	M	MA		MP	M	MA				
				1	TAMBOR COMPLETO	COMPLETE DRUM	P634010000 P634910000 P644010000 P644912000	1	1									
2	POLEA	PULLEY	P626006000 P646013000	1	1	1	1	1	1	1								
3	CORREA	BELT	P635902000	1	1										02,05,11			
			P625903000	1	1											02,05,11		
			P635902000			1	1	1										
			P635908000							1	1							
			P645905000									1	1	1				
4	RETEN V-RING 1	V-RING RETAINER 1	P624914000	1	1													
			P634912000			1	1	1	1	1								
			P644916000									1	1	1				
5	RETEN V-RING 2	V-RING RETAINER 2	P624913000	1	1													
			P634911000			1	1	1	1	1								
			P644915000									1	1	1				
6	ARANDELA POLEA	PULLEY WASHER	P626012000	1	1	1	1	1	1	1								
7	CHAVETA	COTTER PIN	P626010000	1	1	1	1	1	1	1								
8	ARANDELA SEGURIDAD	SAFETY WASHER	Q301329000	1	1	1	1	1	1	1								
9	TORNILLO POLEA	PULLEY SCREW	Q011376000	1	1	1	1	1	1	1								
10	ARANDELA A5	WASHER A5	Q232030000	1	1	1	1	1	1	1								
11	ARAND.ABAN. A5 A.304	FAN WASHER A5 A.304	Q242030000	1	1	1	1	1	1	1								
12	TORN.EXA. M5X15 A.304	HEX BOLT M5X15 A.304	Q012032000	1	1	1	1	1	1	1								
13	MOTOR	ENGINE	P635906000	1	1	1	1	1										
			P645902000						1	1			1	1	1			
14	TUBO SOPORTE MOTOR	MOTOR SUPPORT HOSE	P635907000	2	2	2	2	2										
			P645903000						2	2			2	2	2			
15	TORNILLO MOTOR	MOTOR SCREW	Q151527000	2	2	2	2	2										
			Q151591000						2	2			2	2	2			
16	TENSOR MOTOR	MOTOR TENSOR	P620214000	1	1	1	1	1	1	1								
17	TORNILLO TENSOR	TENSOR SCREW	Q151393000	1	1	1	1	1	1	1								

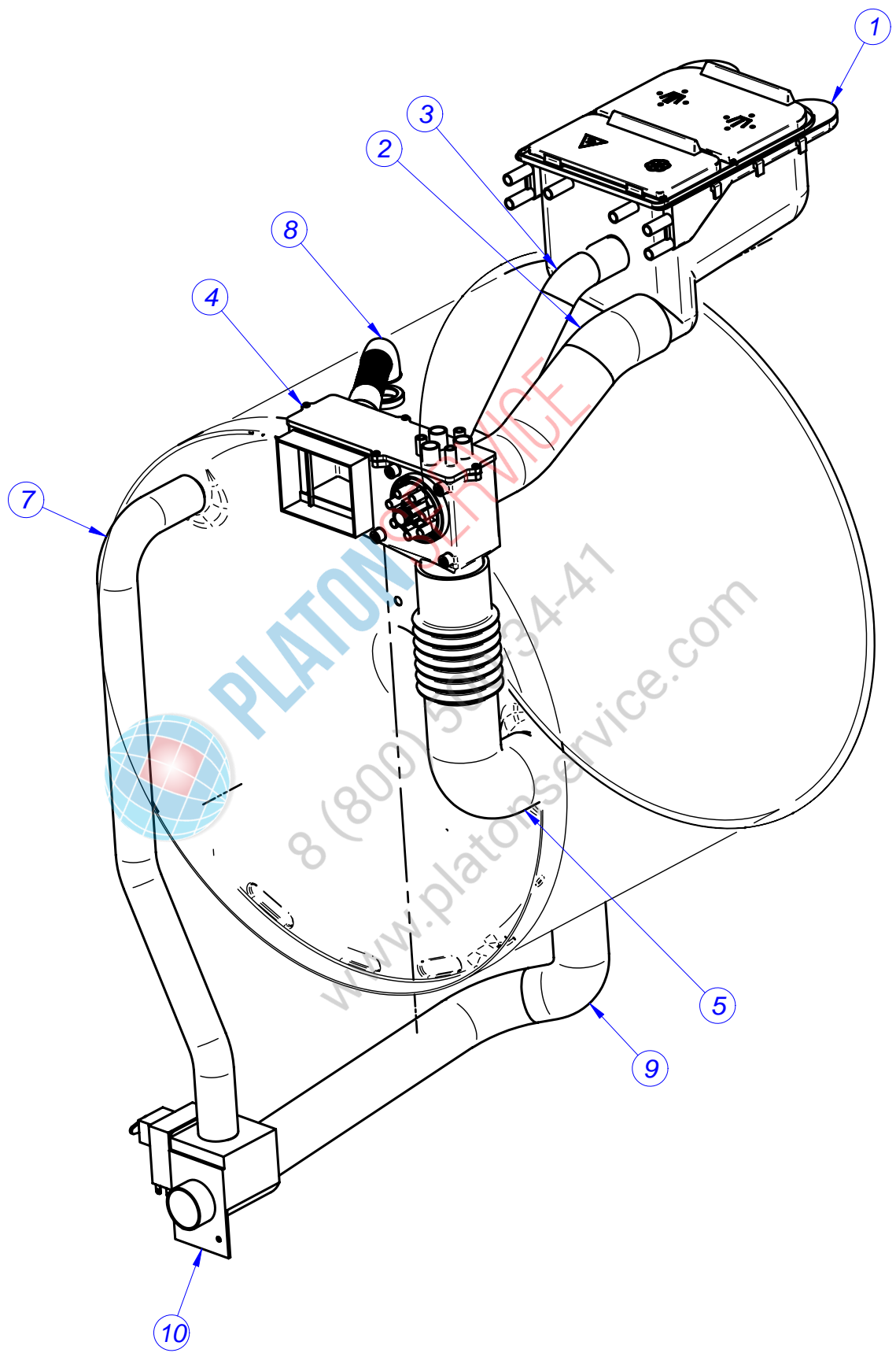

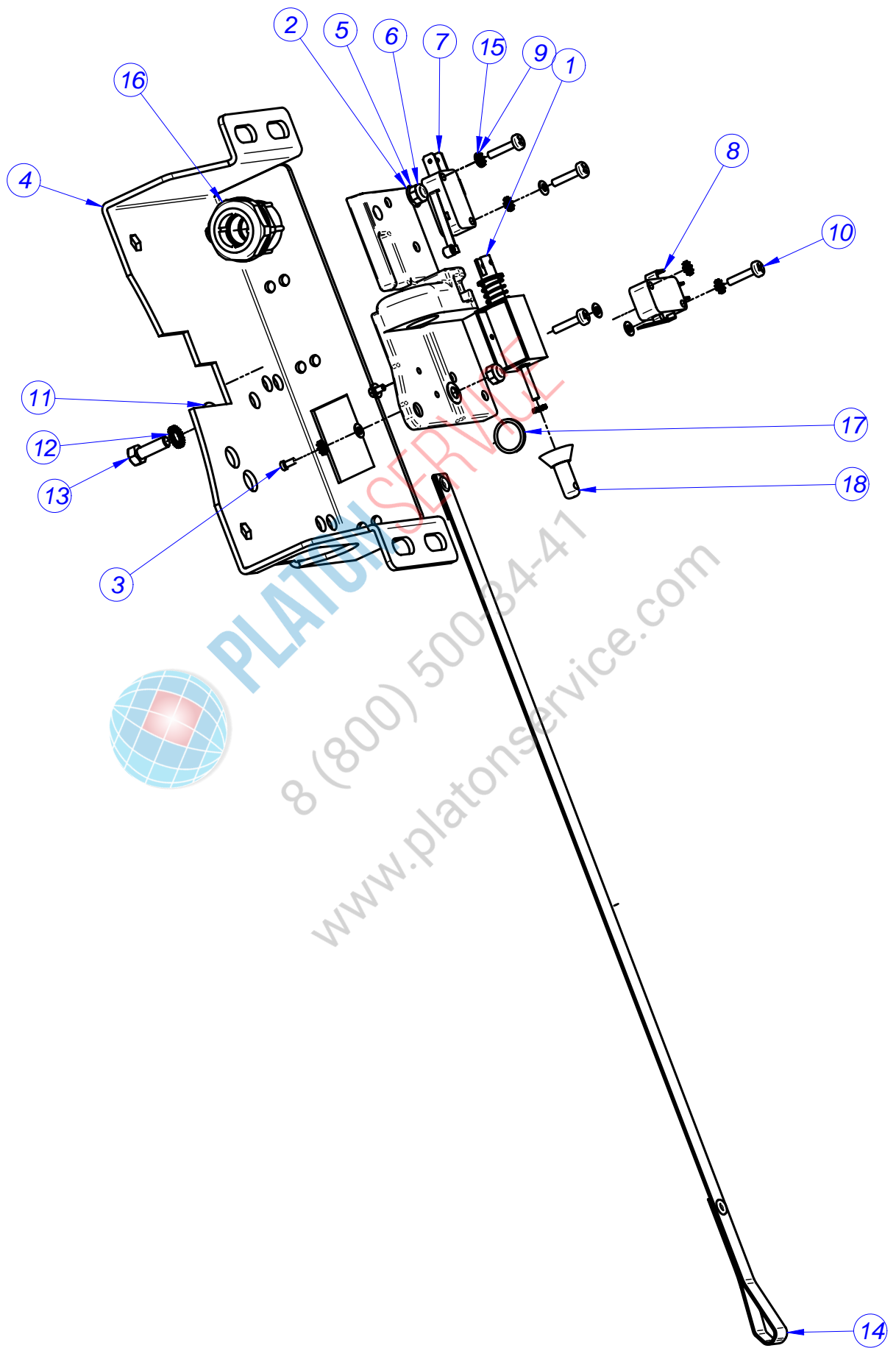

PLATONS SERVICE
8 (800) 500-34-41
www.platonservice.com

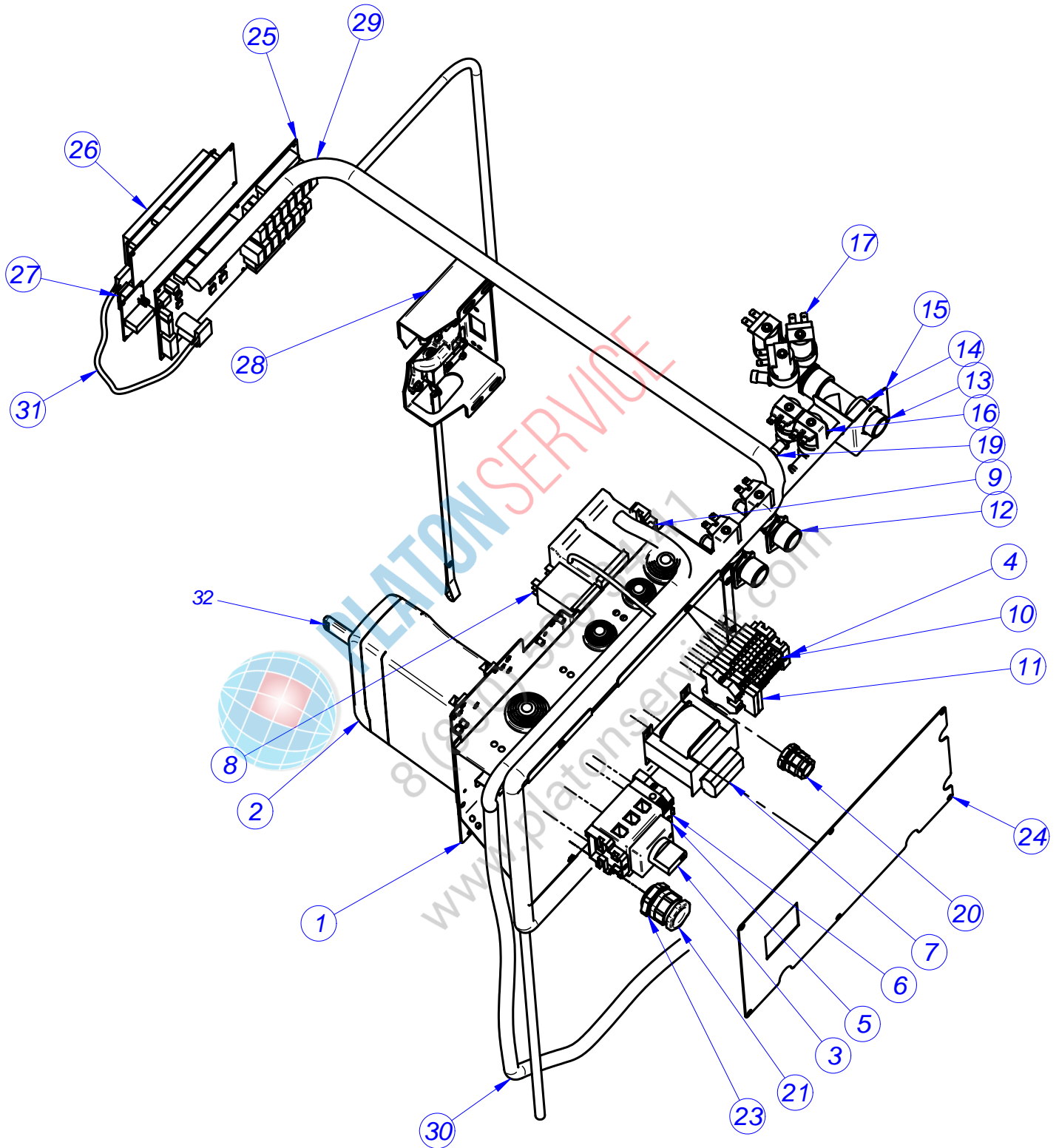

CUADRO ELECTRICO / ELECTRIC PANEL

ITEM	DENOMINACION	NAME	CODIGO	LR-18			LA-18			LR-25			LA-25						ELIMINADO ELIMINATED	INTRODUCID O INTRODUCED																
				M			MA			MP			M			MA					MP			M			MA									
	E	AC	V	E	AC	V	E	AC	V	E	AC	V	E	AC	V	E	AC	V			E	AC	V	E	AC	V	E	AC	V	E	AC	V	E	AC	V	
1	PORTA CUADRO ELECTRICO	ELCTRIC PANEL HOLDER	P620347000	1	1	1	1	1	1																											
			P644020000							1	1	1	1	1	1	1	1	1	1	1	1	1	1	1	1	1	1	1	1	1	1	1	1	1	1	1
2	VARIADOR PROGRAM. 25 400 V.	VARIATOR PROGRAM. 25 400 V.	P633010000	1	1	1	1	1	1	1	1	1	1	1	1	1	1	1	1	1	1	1	1	1	1	1	1	1	1	1	1	1	1			
			P643012000																1	1	1	1	1	1	1	1	1	1	1	1	1	1	1			
2	VARIADOR PROGRAM. 25 230 V.	VARIATOR PROGRAM. 25 230 V.	P643013000													1	1	1	1	1	1	1	1	1	1	1	1	1	1	1	1	1	1			
			P623003000				1	1	1	1	1	1	1	1	1	1	1	1	1	1	1	1	1	1	1	1	1	1	1	1	1	1	1			
3	SECCIONADOR	CIRCUIT BREAKER	P537038000	1		1	1		1	1		1	1		1	1		1	1		1	1		1	1		1	1		1	1		1			
			Z263303000	3	3	3	3	3	3	3	3	3	3	3	3	3	3	3	3	3	3	3	3	3	3	3	3	3	3	3	3	3	3	3	3	3
4	TOPE FINAL	END STOP	R673010000	1		1	1		1	1		1	1		1	1		1	1		1	1		1	1		1	1		1	1		1			
5	BORNA AZUL	BLUE TERMINAL	Z103035000	1	1	1	1	1	1	1	1	1	1	1	1	1	1	1	1	1	1	1	1	1	1	1	1	1	1	1	1	1	1			
6	BORNA TIERRA	EARTH TERMINAL	P623028000	1	1	1	1	1	1	1	1	1	1	1	1	1	1	1	1	1	1	1	1	1	1	1	1	1	1	1	1	1	1			
7	TRANSFORMADOR	TRANSFORMER	Z203062000	1	1	1	1	1	1	1	1	1	1	1	1	1	1	1	1	1	1	1	1	1	1	1	1	1	1	1	1	1	1			
			Z213007000													1	1	1	1	1	1	1	1	1	1	1	1	1	1	1	1	1	1			
9	CONTACTOR	CONTACTOR	Z203050000	2		2	2		2	2		2	2		2	2		2	2		2	2		2	2		2	2		2	2		2			
			Z743009000		1	1		1	1		1	1		1	1		1	1		1	1		1	1		1	1		1	1		1	1		1	1
			12041014													2		2	2		2	2		2	2		2	2		2	2		2			
			Z103070000													1		1	1		1	1		1	1		1	1		1	1		1			
10	REGLETA DOSIFICACION	DISPENSER TERMINAL STRIF	P623006000	5	5	5	7	7	8	8	8	8	5	5	5	7	7	7	5	5	5	7	7	7	8	8	8	5	5	5	7	7	7			
11	BORNA PORTAFUSIBLE	FUSEHOLDER TERMINAL	R073005000	2	2	2	2	2	2	2	2	2	2	2	2	2	2	2	2	2	2	2	2	2	2	2	2	2	2	2	2	2	2			
12	ELECTROVALVULA SIMPLE	SIMPLE SOLENOID VALVE	Z701135000	1	1	1	1	1	2	2	2	2	1	1	1	1	1	1	1	1	1	1	1	1	1	1	1	1	1	1	1	1	1			
			Z102305000													2	2	2	2	2	2	2	2	2	2	2	2	2	2	2	2	2	2			
			Z102323000													2	2	2	2	2	2	2	2	2	2	2	2	2	2	2	2	2	2			
			P533009000													2	2	2	2	2	2	2	2	2	2	2	2	2	2	2	2	2	2			
13	RACOR 3/4"	3/4" CONNECTION	Z102301000	1	1	1	1	1	1	1	1	1	1	1	1	1	1	1	3	3	3	3	3	3	4	4	4	3	3	3	3	3	3			
14	Te A 90°	T at 90°	P535020000	1	1	1	1	1	1	1	1	1	1	1	1	1	1	1	1	1	1	1	1	1	1	1	1	1	1	1	1	1	1			
15	TOPE ELECTROVALVULA	SOLENOID VALVE STOP	P535003000	1	1	1	1	1	1	1	1	1	1	1	1	1	1	1	1	1	1	1	1	1	1	1	1	1	1	1	1	1	1			
16	ELECTROVALVULA DOBLE	DOUBLE SOLENOID VALVE	P255001000	1	1	1	1	1	1	1	1	1	1	1	1	1	1	1	1	1	1	1	1	1	1	1	1	1	1	1	1	1	1			
17	ELECTROVALVULA TRIPLE	TRIPLE SOLENOID VALVE	Z611123000	1	1	1	1	1	1	1	1	1	1	1	1	1	1	1	1	1	1	1	1	1	1	1	1	1	1	1	1	1	1			
19	REGULADOR VERDE	GREEN REGULATOR	P443042000	2	2	2	2	2	2	2	2	2	2	2	2	2	2	2	2	2	2	2	2	2	2	2	2	2	2	2	2	2	2			
20	PRENSA ESTOPA DOSIFICACION	DISPENSER STUFFING BOX	R073004000	1	1	1	1	1	1	1	1	1	1	1	1	1	1	1	1	1	1	1	1	1	1	1	1	1	1	1	1	1	1			
21	PRENSA ESTOPA PG-21	STUFFING BOX PG-21	R023013000	1	1	1	1	1	1	1	1	1	1	1	1	1	1	1	1	1	1	1	1	1	1	1	1	1	1	1	1	1	1			
22	JUNTA GOMA	RUBBER SEAL	R023026000	1	1	1	1	1	1	1	1	1	1	1	1	1	1	1	1	1	1	1	1	1	1	1	1	1	1	1	1	1	1			
23	TUERCA ROSCA Pg 21	SCREW THREAD Pg 21	Q223016000	1	1	1	1	1	1	1	1	1	1	1	1	1	1	1	1	1	1	1	1	1	1	1	1	1	1	1	1	1	1			
24	TAPA CONEXIONES	CONNECTIONS COVER	P610354000	1	1	1	1	1	1	1	1	1	1	1	1	1	1	1	1	1	1	1	1	1	1	1	1	1	1	1	1	1	1			
			P620383000	1		1	1		1	1		1	1		1	1		1	1		1	1		1	1		1	1		1	1		1			
25	PLACA ENTRADAS-SALIDAS	INLET-OUTLET PLATE	P613025000	1	1	1	1	1	1	1	1	1	1	1	1	1	1	1	1	1	1	1	1	1	1	1	1	1	1	1	1	1	1			
			P613005000							1	1	1										1	1	1				1	1	1	1	1	1			
26	VISUALIZADOR	VIEWER	P613018000	1	1	1	1	1	1	1	1	1	1	1	1	1	1	1	1	1	1	1	1	1	1	1	1	1	1	1	1	1	1			
			P643008000							1	1	1										1	1	1				1	1	1	1	1	1			
S/Nº	DISTANCIADOR M3	SPACER M3	T133007000	20	20	20	20	20	20	20	20	20	20	20	20	20	20	20	20	20	20	20	20	20	20	20	20	20	20	20	20	20	20			

CUADRO ELECTRICO / ELECTRIC PANEL															ELIMINADO ELIMINATED	INTRODUCIDO INTRODUCED													
ITEM	DENOMINACION	NAME	CODIGO	LR-18			LA-18						LR-25				LA-25												
	CALENTAMIENTO			M	MA		MP			M			MA				M			MA									
				E	AC	V	E	AC	V	E	AC	V	E	AC			V	E	AC	V	E	AC	V	E	AC	V			
27	INTERRUPTOR GENERAL	POWER SWITCH	Z218030000	1	1	1				1	1	1	1	1	1				1	1	1	1	1	1	1	1	1		
			P623025000																									1	1
S/Nº	PORTA INTERRUPTOR C.I. V2	C.I. V2 SWITCH HOLDER	P640325000	1	1	1				1	1	1	1	1	1				1	1	1	1	1	1	1	1	1		
28	CIERRE COMPLETO	COMPLETE LOCK	P620516000																										
			P620531000	1	1	1	1	1	1	1	1	1	1	1	1	1	1	1	1	1	1	1	1	1	1	1	1	1	1
29	INSTALACION GENERAL	GENERAL INSTALLATION	P623033000	1	1	1	1	1	1	1	1	1	1	1	1	1	1	1	1	1	1	1	1	1	1	1	1	1	1
			P643002000										1	1	1	1	1	1	1	1	1	1	1	1	1	1	1	1	1
30	CABLE CALENTAMIENTO	HEATING CABLE	P613015000							1												1			1				
			P613016000		1	1					1			1						1			1			1			
			P623008000	1				1												1			1			1			
			P643003000										1				1			1			1			1			
31	CABLE COMUNICACION	COMMUNICATION CABLE	P623026000	1	1	1	1	1	1				1	1	1	1	1	1	1	1	1	1	1	1	1	1	1	1	1
			P623009000							1	1	1							1	1	1								
32	PLC PROGRAMADO 2,2KW	PLC PROGRAMMED 2.2KW	P633015000	1	1	1	1	1	1	1	1	1	1	1	1	1	1	1	1	1	1	1	1	1	1	1	1	1	1
32	PLC PROGRAMADO 3KW	PLC PROGRAMMED 3KW	P643029000										1	1	1	1	1	1	1	1	1	1	1	1	1	1	1	1	1
32	PLC PROGRAMADO 4KW 400V	PLC PROGRAMMED 4KW 400V	P643030000										1	1	1	1	1	1	1	1	1	1	1	1	1	1	1	1	1
32	PLC PROGRAMADO 4KW 230V	PLC PROGRAMMED 4KW 230V	P643031000										1	1	1	1	1	1	1	1	1	1	1	1	1	1	1	1	1

VARIOS / VARIOUS																										ELIMINADO ELIMINATED	INTRODUCIDO INTRODUCED				
ITEM	DENOMINACION	NAME	CODIGO	LR-18			LA-18						LR-25			LA-25															
	CALENTAMIENTO			M	MA		MP			M			MA			M			MA												
				E	AC	V	E	AC	V	E	AC	V	E	AC	V	E	AC	V	E	AC	V	E	AC	V	E			AC	V		
	CABLEADO INTERRUP-GENER.	SWITCH WIRING-GENERAL	12025118	1	1	1			1	1	1	1	1	1			1	1	1			1	1	1	1	1	1				
	CABLE. PTC+PUENTE RECTIFIC.	PTC + WIRING BRIDGE-RECTIF.	12025061	1	1	1	1	1	1	1	1	1	1	1	1	1	1	1	1	1	1	1	1	1	1	1	1	1			
	CABLEAD. RESISTENCIA L-8 13	WIRING RESISTANCE L-8 13	12024944	1			1			1			1									1			1			1			
	CABLEADO TECLADO-SIMPLE	WIRED KEYBOARD-SIMPLE	12023293	1	1	1	1	1			1	1	1	1	1	1	1	1	1	1			1	1	1	1	1				
	CABLEADO TRANS.SIN NEUTRO	NO NEUTRAL WIRE TRANSFOR.	12025104	1																											
	CABLEADO ARRASTRE-AC	TRAILING WIRING-AC	12025082		1			1			1			1	1																
	CABLE. ELECTR. VALV.VAPOR	WIRING ELECTROVALV.VAPOR	12025067		1				1			1						1					1			1					
	CABL.CONECTOR-PUENTE-LIM	WIRING CONN.-BRIDGE-POWER	12025206				1	1					1	1	1	1	1	1	1	1	1	1	1	1	1	1	1	1	1		
	CABLEADO MONEDERO C.P.	WIRED PURSE C.P	12009766				1	1					1	1				1	1	1						1	1				
	CABLEADO PROG.MP	PROGRAMMED WIRING MP	12025136					1	1	1												1	1	1							
	CABLEADO AGUA-CALIENTE	HOT WATER WIRING 8/13/18	12024818						1			1																			
	CABLEADO RESISTENCIA LA 25	WIRING RESISTANCE LA 25	12024832													1			1					1			1				

Instalaciones	Referencia	LAV-10	LAV-13	LAV-18	Notas
Placa relés M	P-613019000	X	X	X	
Circuito teclado display	P-613018000	X	X	X	
Indicador de componentes Lav	P-623011000	X	X	X	
Interruptor general C.I.	P-623017000	X	X	X	
Leyenda Lav	P-623014000	X	X	X	
Componentes	Reference	LAV-10	LAV-13	LAV-18	
Borne doble piso 2,5mm Weidmuller DK 4/35 5276.6	P-623006000	7	7	7	
Borne Azul 10mm	Z-263302000	1	1	1	
Borne Portafusible	R-073005000	2	2	2	
Borne tierra 10mm	P-453026000	2	2	2	
Condensador antiparasitario 0,1 uF	Z-233012000	7	7	7	
Contactador 20A NA	Z-203050000	2	2	2	
Contactador 35 A	P-433030000				
Contactador 60 A	X-183011000				
Electrovalvula simple	Z-701135000	2	2	2	
Electrovalvula doble	P-255001000	X	X	X	
Electrovalvula Triple	Z-611123000	X	X	X	
Electrovalvula simple 120 L/h Z-102305	Z-102323000				
Electroiman Biestable	P-613002000	X	X	X	
Fusible 4A	P-184011000	2	2	2	
Interuptor magnetico desequilibrio NA	Z-100522000	X	X	X	
Monedero	P-613004000	X	X	X	
Motor 10	P-615904000	X			
Motor 13	P-625905000		X		
Motor 18	P-635906000			X	
PG-21 Prensaestopas	R-023013000	X	X	X	
PG21 Tuerca	Q-223016000	X	X	X	
PG21 Junta de goma					
PG36 Junta de goma					
PG36 Prensaestopas	R-143010000				
PG36 Tuerca					
Regleta 2,5 mm ² TEKOX1106PL D.int = 3,2mm	R-693010000	2/12	2/12	2/12	
Regleta 6 mm ² 1/12 D.int = 4,1mm	Z-713035000				
Regleta 16 mm ² 1/6 Elettro Gibi D.int = 5,5mm	Z-743006000				
Rele 16 A 2NA 230V 50/60Hz Faston FINDER	Z-203062000	X	X	X	
Resistencia 2KW 8KG	P-613008000	3			
Resistencia 3KW 13KG	P-623005000		3		
Resistencia 4KW 18KG	P-633002000			3	
Resistencia 6KW	P-533001000				
Señalización R,S,T,N,PE	Z-683068000	X	X	X	
Seccionador 8KG 32A 11,5kw Siemens 3LD22 30-OTK13	P-623003000	X			
Seccionador 13,18,25KG 63 A 22 kw Siemens 3LD25 30-OTK13	P-537038000		X	X	
Seccionador 125 A 45 Kw Siemens 3LD28 30-OTK13	P-543039000				
Sonda NTC + Limitador	P-503025000	X	X	X	
Terminal mini Mate-n-lok Hembra 170362-1	P-623016000				
Tope final 10mm	Z-263303000	X	X	X	
Tapa Cubierta conector Sub-D	P-613014000	X	X	X	
Transformador 230/20-0-20 24-0	P-623004000	X	X	X	
Variador 10Kg	P-613007000	X			
Variador 13Kg	P-623002000		X		
Variador 18Kg	P-633003000			X	
Valvula de vaciado 8, 13, 18 Kg	P-302120000	X	X	X	

Installations	Reference	LAV-10	LAV-13	LAV-18	Notes
Relay plate M	P-613019000	X	X	X	
Keyboard display circuit	P-613018000	X	X	X	
Wash components display	P-623011000	X	X	X	
C.I. Power switch	P-623017000	X	X	X	
Wash legend	P-623014000	X	X	X	
Components	Reference	LAV-10	LAV-13	LAV-18	
Double floor terminal 2.5 mm Weidmuller DK 4/35 5276.6	P-623006000	7	7	7	
Blue terminal 10 mm	Z-263302000	1	1	1	
Fuse holder terminal	R-073005000	2	2	2	
Earth terminal 10 mm	P-453026000	2	2	2	
Antiparasitic condenser 0.1 uF	Z-233012000	7	7	7	
Contactora 20A NA	Z-203050000	2	2	2	
Contactora 35 A	P-433030000				
Contactora 60 A	X-183011000				
Simple solenoid valve	Z-701135000	2	2	2	
Double solenoid valve	P-255001000	X	X	X	
Triple solenoid valve	Z-611123000	X	X	X	
Simple solenoid valve 120 L/h Z-102305	Z-102323000				
Bistable electromagnet	P-613002000	X	X	X	
4A fuse	P-184011000	2	2	2	
Imbalance magnetic switch NA	Z-100522000	X	X	X	
Coin slot.	P-613004000	X	X	X	
Motor 10	P-615904000	X			
Motor 13	P-625905000		X		
Motor 18	P-635906000			X	
PG-21 Packing glands	R-023013000	X	X	X	
PG21 Nut	Q-223016000	X	X	X	
PG21 Rubber seal					
PG36 Rubber seal					
PG36 Packing gland	R-143010000				
PG36 Nut					
Terminal strip 2.5 mm ² TEKOX1106PL Int. diam. = 3.2 mm	R-693010000	2/12	2/12	2/12	
Terminal strip 6 mm ² 1/12 Int. diam. = 4.1 mm	Z-713035000				
Terminal strip 16 mm ² 1/6 Elettro Gibi Int. Diam. = 5.5 mm	Z-743006000				
Relay 16 A 2NA 230V 50/60Hz Faston FINDER	Z-203062000	X	X	X	
Resistance 2KW 8KG	P-613008000	3			
Resistance 3KW 13KG	P-623005000		3		
Resistance 4KW 18KG	P-633002000			3	
Resistance 6KW	P-533001000				
R,S,T,N,PE indication	Z-683068000	X	X	X	
Circuit Breaker 8KG 32A 11.5kw Siemens 3LD22 30-OTK13	P-623003000	X			
Circuit Breaker 13,18,25 KG 63 A 22 kw Siemens 3LD25 30-OTK13	P-537038000		X	X	
Circuit Breaker 125 A 45 Kw Siemens 3LD28 30-OTK13	P-543039000				
NTC probe + Limiter	P-503025000	X	X	X	
Mini terminal Mate-n-lok female socket 170362-1	P-623016000				
End buffer 10 mm	Z-263303000	X	X	X	
Cover lid connector Sub-D	P-613014000	X	X	X	
Transformer 230/20-0-20 24-0	P-623004000	X	X	X	
Variator 10 Kg	P-613007000	X			
Variator 13 Kg	P-623002000		X		
Variator 18 Kg	P-633003000			X	
Drainage valve 8, 13, 18 Kg	P-302120000	X	X	X	

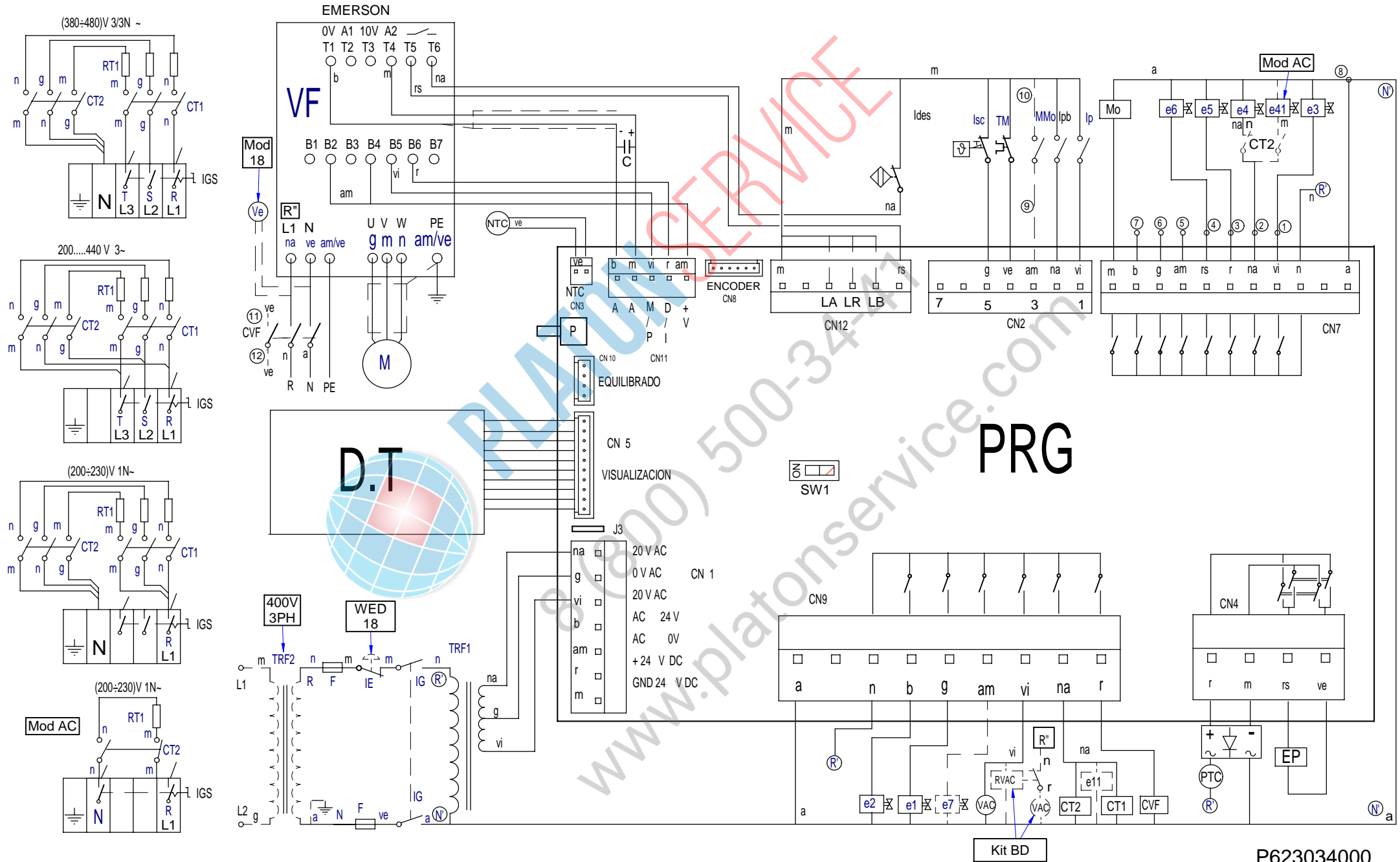

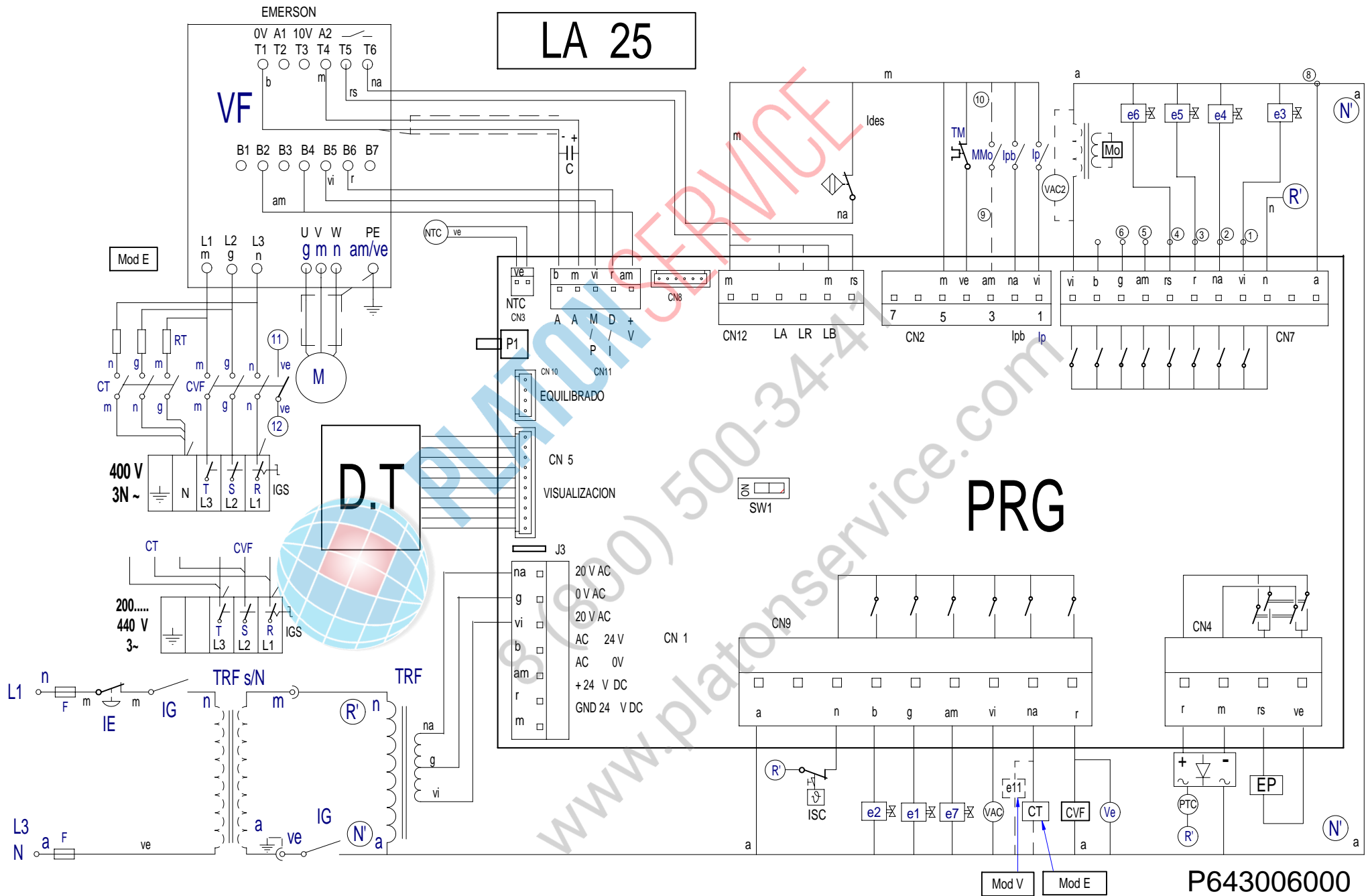

Simb / LENG	ESPAÑOL	FRANÇAIS	ENGLISH	DEUTSCH	ITALIANO
CT =	Contacto Calentamiento	Contacteur Chauffe	Heating Contactor	Heizschütz	Contatore Riscaldamento
DP =	Detector posición.	Détecteur position	Position detector	Stellung Taster	Rilevatore posizione
DS1	Dosificador Neutralizante.	Doseur Neutralisant	Neutralizer feeder	Dosiervorrichtung Neutralpulmittel	Dosatore Neutralizzante
DS2	Dosificador jabon liquido.	Doseur lessive liquide	Liquid soap feeder	Dosiervorrichtung Flüssigseife	Dosatore sapone liquido
DS3	Dosificador aditivos.	Doseur additifs	Additive feeder	Dosiervorrichtung Zusatzmittel	Dosatore additivi
D.T.	Display/Teclado	Ecran/Clavier	Display/Keyboard	Display/Tastatur	Display/Tastiera
e1 =	Electro válvula agua Fria.	Électrovanne eau Froide	Cold water electrically operated valve	Elektroventil Kaltwasser	Elettrovalvola acqua Fredda
e2 =	Electro válvula agua Caliente	Électrovanne eau Chaude	Hot water electrically operated valve	Elektroventil Warmwasser	Elettrovalvola acqua Calda
e3 =	Electro válvula Prelavado.	Électrovanne Prélavage	Pre-wash electrically operated valve	Elektroventil Vorwaschen	Elettrovalvola Prelavaggio
e4 =	Electro válvula Lavado.	Électrovanne Lavage	Wash electrically operated valve	Elektroventil Hauptwaschgang	Elettrovalvola Lavaggio
e5 =	Electro válvula Lejía.	Électrovanne Eau de Javel	Bleach electrically operated valve.	Elektroventil Bleiche	Elettrovalvola Candeggina
e6 =	Electro válvula Suavizante.	Électrovanne Assouplissant	Fabric softener electrically operated valve	Elektroventil Weichspüler	Elettrovalvola Ammorbidente
e7 =	Electro válvula agua Descalcificada	Électrovanne eau Adoucie	Delimed water electrically operated valve	Elektroventil entkalktes Wasser	Elettrovalvola acqua Decalcificata
e8 ,9,10 =	Electro válvula Equilibrado	Électrovanne Équilibrage	Balancer electrically operated valve	Elektroventil Gleichgewicht	Elettrovalvola Bilanciamento
e11 =	Electro válvula Vapor.	Électrovanne Vapeur	Steam electrically operated valve	Elektroventil Dampf	Equilibrado Vapore
EP =	Electroiman de Puerta.	Électro-aimant de Porte	Door electric magnet	Elektromagnet Gerätetür	Electromagnete Porta
FI =	Filtro de Interferencias.	Filtre Anti-parasites	Interference filter	Störungsfilter	Filtro Interferenze
F =	Fusible.	Fusible	Fuse	Sicherung	Fusibile
G1,G2 =	Galga Sensor.	Jauge Capteur	Sensing gage	Meßsensor	Calibro Sensore
IE =	Pulsador Parada de emergencia.	Bouton-poussoir Arrêt d'urgence	Emergency stop push button	Not-Aus-Taster	Pulsante Arresto di emergenza
IG =	Interruptor general.	Interrupteur général	General switch	Hauptschalter	Interruttore generale
IGS =	Interruptor General de seguridad.	interrupteur Général de sécurité	General safety switch	Sicherheitshauptschalter	Interruttore Generale di sicurezza
Ides =	Intruptor de desequilibrio.	Interrupteur de balourd	Unbalance switch	Ungleichgewichtsschalter	Interruttore di squilibrio
IMo =	Interruptor Monedero.	Interrupteur Monnayeur	Coin slot switch	Münzschalter	Interruttore Portamonete
Ip =	Interruptor puerta Cerrada.	Interrupteur porte Fermée	Closed door switch	Schalter Tür geschlossen	Interruttore porta Chiusa
Ipb =	Interruptor puerta bloqueada.	Interrupteur porte verrouillée	Door lock switch	Schalter Tür verriegelt	Interruttore porta bloccata
Isc =	Interruptor seguridad Temperatura	Thermostat Limiteur	Hi-limit Thermostat	Grenzthermostat	Termostato Limitatore
M =	Motor.	Moteur	Motor	Motor	Motore
Mo =	Monedero.	Monnayeur	Coin slot	Münzvorrichtung	Portamonete
NTC =	Sensor temperatura..	Capteur température	Temperature sensor	Temperatursensor	Sensore temperatura
RT =	Resistencia Calentamiento.	Résistance Chauffe	Heating Resistors	Widerstand Aufheizung	Resistenza Riscaldamento
Tm =	Térmico de Motor.	Thermique du Moteur	Motor hot-wire	Motorwärmeschalter	Termico del Motore
Tfr =	Transformador	Transformateur	Transformer	Transformator	Trasformatore
Tfr s/N =	Transformador Versión sin Neutro.	Transformateur Version sans Neutre	Transformer Version without Neutral	Transformator Modell ohne Neutralstellung	Trasformatore Versione senza Neutro
VAC =	Válvula Vaciado	Vanne Vidange	Emptying valve	Ablassventil	Valvola Scarico
Ve =	Ventilador.	Ventilateur	Fan	Ventilator	Ventola
VF =	Convertidor de Frecuencia.	Convertisseur de Fréquence	Frequency converter	Frequenzumwandler	Convertitore di Frequenza
VM =	Ventilador Motor.	Ventilateur Moteur	Fan motor	Ventilator Motor	Ventola Motore
1...8 =	Puntos conexión dosificadores.	Points raccordement doseurs	Feeder connection points	Anschlussstellen Dosiervorrichtungen	Punti connessione dosatori
COLOR	COLORES	COULEURS	COLOUR	FARBEN	COLORE
a =	Azul	Bleu	Blue	Blau	Blu
am =	Amarillo	Jaune	Yellow	Gelb	Giallo
am/ve =	Amarillo/Verde	Jaune / vert	Yellow / green	Gelb/grun	Giallo/verde
b =	Blanco	Blanc	White	Weiß	Bianco
g =	Gris	Gris	Grey	Grau	Grigio
m =	Marrón	Marron	Brown	Braun	Marrone
n =	Negro	Noir	Black	Schwarz	Nero
na =	Naranja	Orange	Orange	Orange	Arancio
r =	Rojo	Rouge	Red	Rot	Rosso
rs =	Rosa	Rose	Pink	Rosa	Roseo
ve =	Verde	Vert	Green	Grün	Verde
vi =	Violeta	Violet	Purple	Violett	Viola